

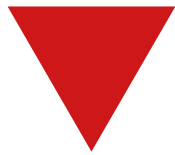

CATALOGUE PAGES



Ixel 1 & 2

Created by Philippe STEPHANT

The lamp IXEL 1 and IXEL 2 are equipped with 50 W – 12 V halogen bulbs.

Identical for the two models, the lighting head moves in all the directions, is tiltable and rotates at 360°. Dual intensity, 35 and 50 W, thanks to a three-position switch located at the base of the arm.

Reflector with sanded glass diffuser anti-UV rays.

Excellent distribution of the light beam onto the work surface.

Lighting head made of Polycarbonate. Arm made of steel wire.

Main lead : 2.5 m Double isolation.

Manufactured in compliance with European standards.

For more information on this product download the technical sheet on www.manade.com

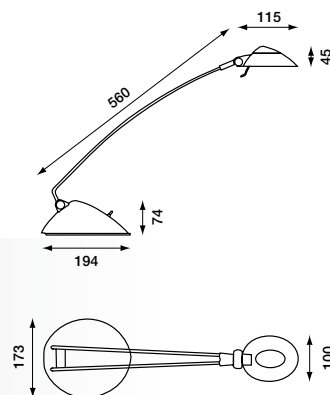
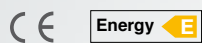

IXEL 1

Model with one single arm, double articulation with friction adjustment system. Amplitude : 0.62 m.

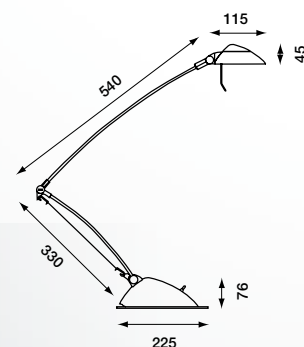

IXEL 2

Model with double arm, triple articulation with friction adjustment system and integrated return spring. Amplitude : 0.95 m.



References

IXEL 1 Black : **IXEL 1 24**

IXEL 1 Silver : **IXEL 1 29**

IXEL 2 Black : **IXEL 2 24**

IXEL 2 Silver : **IXEL 2 29**

